

# ESW-1527A MOBILE SINGLE POST LIFT

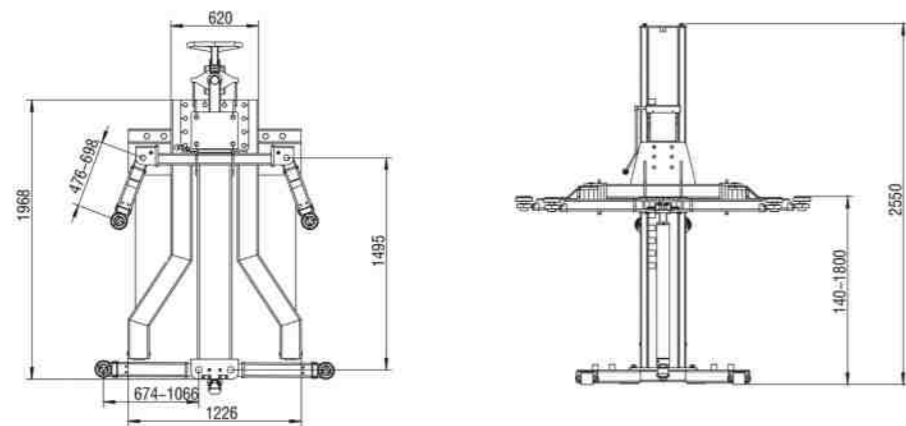

## Features:

The hydraulic parking lift use the platform to support the car, the length and width of supportive point can be adopted by the platform. Compact structure, less space, light weight and convenient to move for steady running. Good quality pump and electronic units, mechanical racks self-lock and hydraulic pressure are adopted, safe and credible. No need the preparation of the basement, place it to the ground is ok.

## Technical specifications:

Lifting capacity:	2700kg
Lifting height:	1800mm
Min.height:	140mm
Lifting time:	50s-60s
Overall height:	2550mm
Motor power:	2.2kw-380v/2.2kw-220v
Oil pressure rating:	24Mpa
Weight:	850kg

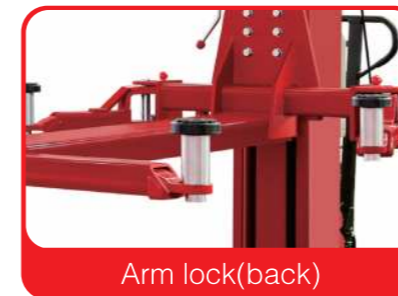

Arm lock(back)

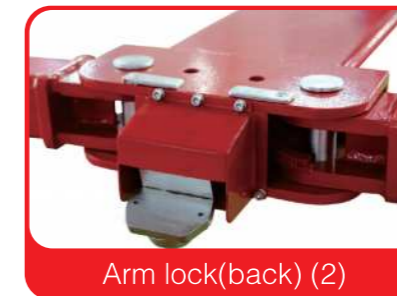

Arm lock(back) (2)



Retractable tray with two screw designed



Manual release



Mobile trolley



Emergency hand pump(optional)